

Quick Installation Guide

(For Windows & Mac OS)

HD IP Camera



V4.9
EQ985308

Package Contents

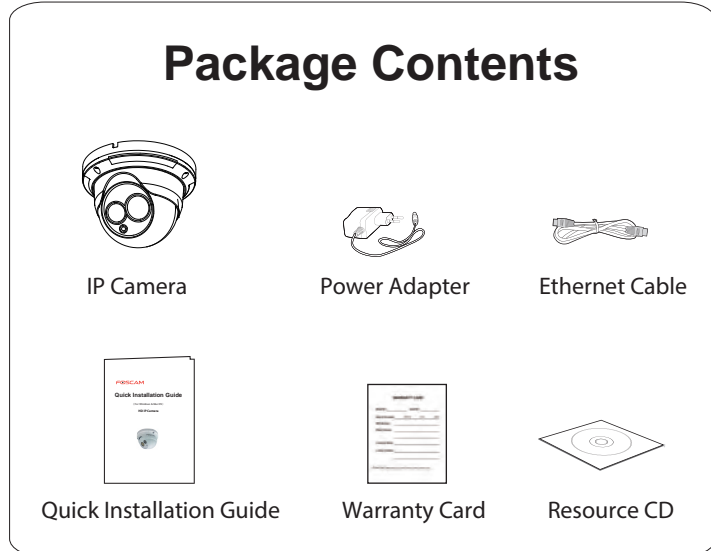

Security Warning

- Foscam cameras and NVRs require good security practices to safeguard your privacy. You should regularly change your camera or NVR password which is 8-10 numbers, letters, symbols combination.
- You should update your camera or NVR regularly. Make sure your camera or NVR has the latest firmware installed for your specific model and better experience.

1 Hardware Introduction

Physical Description

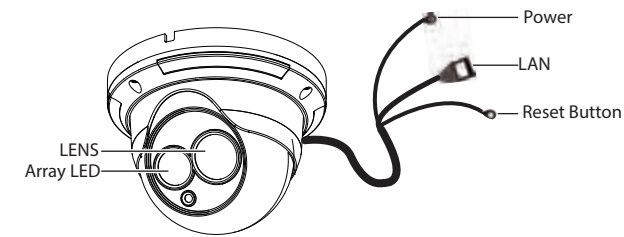

Hardware Installation

1. Loosen the three screws on the base of the camera, remove the camera base.

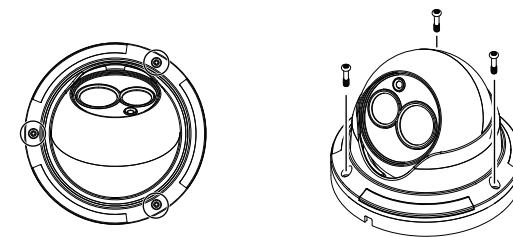

2. According to the monitored area, install the base of the camera on the ceiling or wall with expansion screws.
3. Assembly the sphere, cover and decorative ring of the order, according to the monitored area to turn the angle of the sphere. Finally, fix the decorative ring and the base with screws.

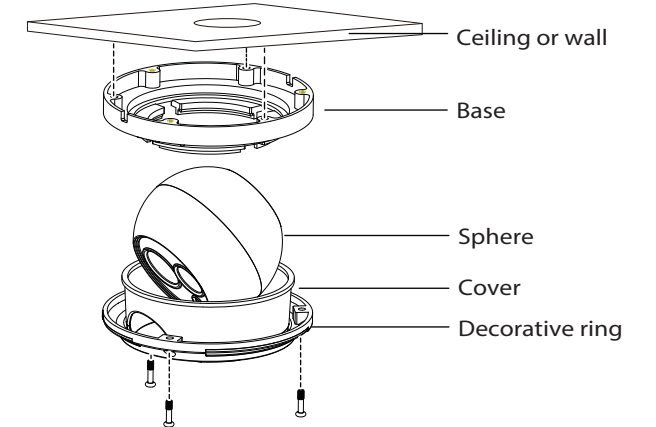

CE Certificate Website:
<http://www.foscam.com/company/ce-certificate.html>

ShenZhen Foscam Intelligent Technology Co., Ltd
www.foscam.com

Hardware Connection

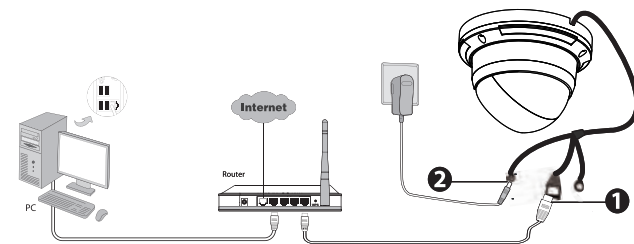

1. Connect the camera to the LAN network (Router or Switch) via network cable.
2. Connect the power adapter to the camera.

2 Software Installation

1. Insert the CD into the CD drive of your computer.
2. Go to the folder "Equipment Search Tool" and find the folder "For Windows OS" or "For Mac OS". Copy and paste the Equipment Search Tool file to your computer, or drag it onto your desktop.



Notes:

- If your computer (Windows OS) supports autorun function, you can find the corresponding file in the opened control panel.
- If your computer doesn't have CD drive, you can download the Equipment Search Tool from our website for free.

3 Access the Camera

1. Enable the DHCP feature of your router (Enabled by default normally), then open the Equipment Search Tool program. It should display the camera's IP address in your LAN (Local Area Network).

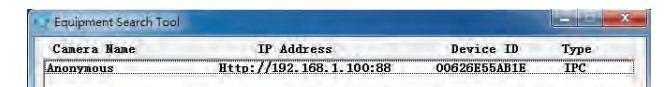

2. Double click the camera list here, and your default browser will open up to the camera's login page. When logging in for the first time, you will need to download and install the add-on. Take Microsoft Internet Explorer as an example. For Google Chrome, Apple Safari, or Mozilla Firefox, please refer to the User Manual.

Note:

Doesn't support 64-bit browser.



3. After installing the add-on, refresh the browser and click **Login**.

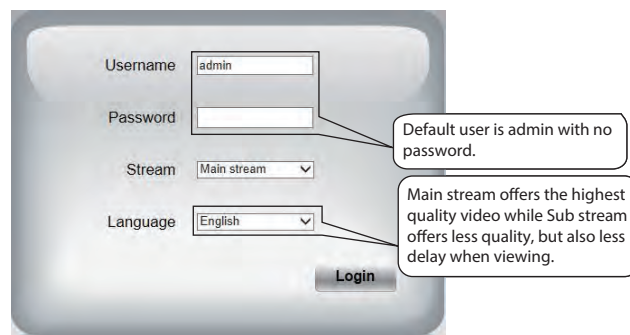

4. When you login for the first time, it will request that you modify the default username and/or password. Input the **New username**, **New password**, and **Confirm the password**, click **Modify** to complete the modification. You will now use the new username and password to login to the camera in the future.

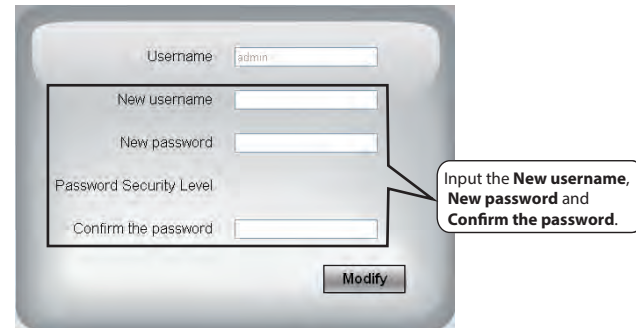

5. After logging in, you should see live video on the interface.

Notes:

- After logging in for the first time, it will go to "Setup Wizard" automatically. Please set the basic parameters, such as camera name, camera time and so on.
- If you forget your username or password, you can press and hold the reset button on the bottom of the camera using a pin for 5 seconds. This resets the camera to factory defaults.

4 Remote Access

If you want to access your camera by web browser outside of your LAN, you need to configure some settings.

1. Choose "Settings" on the top of the camera web page, then go to the "Network > IP Configuration" section on the left side of the screen, then uncheck the **Obtain IP DHCP**.

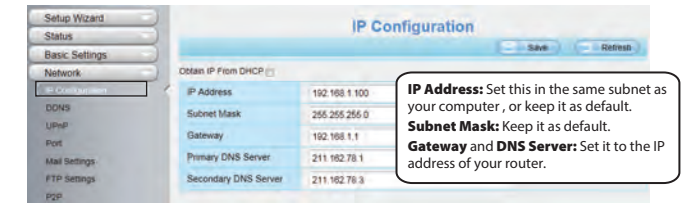

2. Enable UPnP and DDNS in the camera's settings page. We recommend you to use the DDNS by factory default.

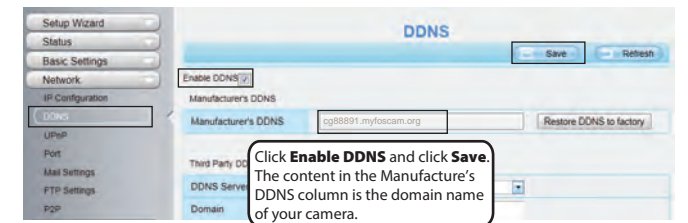
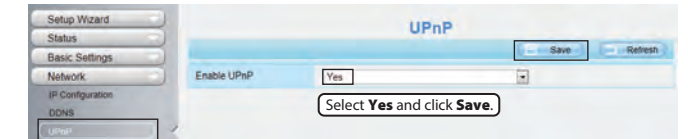

3. You can set the port of your camera here. The value of the port number for each device should be unique.



4. If the UPnP of the router has been enable, you do not need to perform following steps. Otherwise, you need to select one of the following methods to configure port forwarding on your router. For these steps, we will be using the TP-LINK brand wireless router as an example.

- If there is a UPnP function in your router. Choose "Forwarding > UPnP", make sure that the **Current UPnP Status is Enabled**.

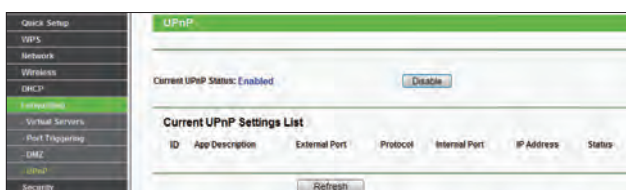

- If there is no UPnP function in your router. You need to manually add port forwarding, refer to the following steps. You need go to the "Forwarding > Virtual Servers" panel for setup.

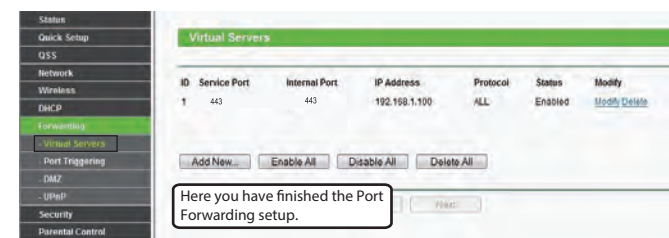
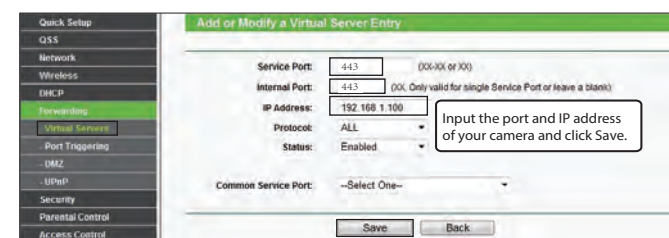

5. Now you can access your IP camera by `https://domain name: HTTPS port via the Internet`.

5 Access the IP Camera by Smart Phone

You can add the Foscam IP Camera using a Smartphone like an iPhone or Android device. Ensure your smartphone is connected to the internet.

Download the Foscam App

If you have a QR Code scanner app on your phone, use it to scan the code below:



Foscam

Please Note:

If you do not have a QR code app on your phone, you can simply go to the App Store or Google Play Store and search for the term "Foscam". Find the app that appears with the same icon as shown above, and then download it to your device.

Add the IP Camera

Run the App, and then register for a Foscam account. Once logged in, you can tap the "+" button on the App and follow the setup wizard to add your camera.

Only with the "Foscam" APP, you can experience new features including Online-Update, Message Push, etc. While with any third-party APP (other than "Foscam"), you do not experience these features.

6 Technical Support

If you have problems with your Foscam IP Camera, please contact the Foscam reseller you purchased from, or you can e-mail the Foscam headquarter technical support team: tech@foscam.com

Your valuable comments and suggestions on improving Foscam products are welcomed!